

2015 Road Profile Users' Group Meeting

# **Sensitivity Analysis of Tire-Road Friction Coefficient to Pavement Texture Parameters Using a Physics-Based Contact Model**

**Ron Kennedy  
Mehran Motamedi  
Saied Taheri  
Corina Sandu**

*Center for Tire Research (CenTiRe)  
Virginia Polytechnic Institute and State University*



# Outline

- **Introduction and Motivation**
- **Pavement Texture and Rubber Friction**
- **Challenges**
- **Objectives**
- **Rubber-Road Friction**
  - **Road Profile Measurement and Characterization**
  - **Friction Estimation**
    - ❑ **Hysteresis and Adhesion**
    - ❑ **Real Area of Contact**
    - ❑ **Sensitivity to Pavement Parameters**
    - ❑ **Thickness of the Excited Layer of Rubber**
  - **Indoor Friction Measurement**
  - **Comparison of Simulations and Experiments**
- **Summary**



# Introduction and Motivation

- Friction between the tire and the road:
  - Pavement surface texture
  - Viscoelastic properties of tread compounds
- Without an accurate rubber-road contact model, even with a detailed tire model, tire dynamics cannot be precisely predicted:
  - Empirical models:
    - ❑ Fit a set of data with empirical equations
  - Physics-based friction models:
    - ❑ More robust predictions



# Pavement Texture and Rubber Friction

- Pavement texture:
  - Feature of the road surface that determines most tire/road interactions.
- Deviations of texture with characteristic dimensions of wavelength and amplitude:
  - Macro-texture
  - Micro-texture
- Friction components:
  - **Hysteresis:** Energy losses generated during local fluctuations of the polymer chains. Deformation energy (induced by surface asperities) is greater recovery energy.
  - **Adhesion:** Tendency of dissimilar particles and surfaces to cling to one another: chemical (intermolecular forces) and dispersive (van der Waals).

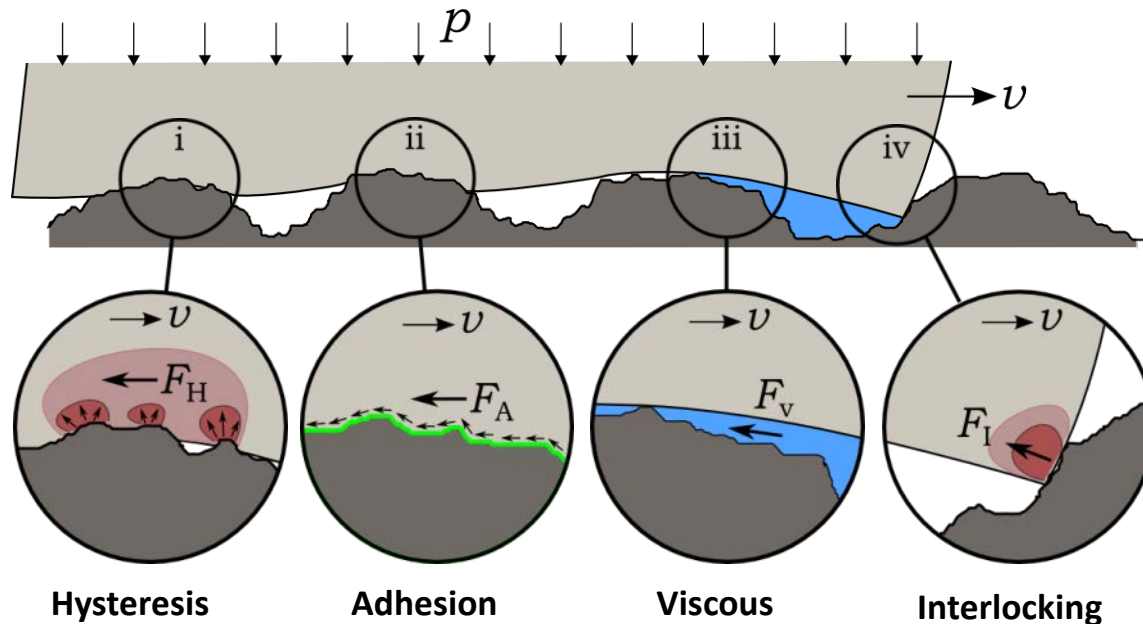

# Challenges

- Precise measurement and effective parametrization of road surfaces
- Measurement and characterization of the viscoelastic behavior of filled rubbers
- Understanding the physics of rubber-road contact
- Mathematical modeling of friction components
- Experimental validation of the theory



# Objectives

- Measure and characterize road surfaces, in terms of frictional properties.
- Develop a competent physics-based contact model for predicting friction of rubber sliding on a rough surface.
- Design and build a dynamic friction tester, to measure the friction between tread compounds and surfaces of choice, and validate the theory.



## Major tasks required to estimate rubber friction:

- Measure the road surface texture
- Parametrize the profiles
- Conduct Dynamic Mechanical Analysis to characterize the tread compounds
- Perform a detailed study of contact mechanics:
  - Study hysteresis and adhesion
  - Estimate the real area of contact
  - Study the effects of sliding velocity, contact pressure and flash heating
  - Investigate the sensitivity of friction to road surface features
  - Develop an inclusive friction model
- Validate the theory through experiments



# Road Surface Measurement

- **Nanovea JR25:** Portable optical profilometer

It is shown that road profiles are fractal, and that this fractality is related to the friction properties of the road.

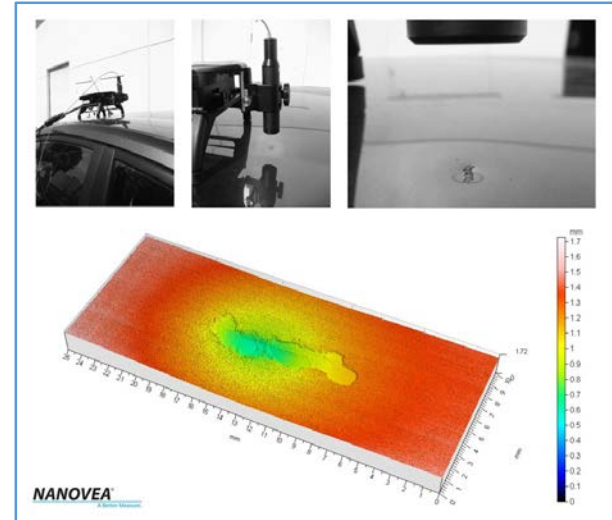

## Characterization of Fractal Road Profiles

- **1-Dimensional:**
  - Height Difference Correlation Function (Kluppel)
  - Power Spectral Density of line-scan (Rado)
- **2-Dimensional:**
  - Power Spectral Density of Area (Persson)
    - ❑ *2D profiles are time consuming to measure and computationally expensive to analyze*
  - 2D PSD can be obtained from the 1D PSD, for the limiting cases of:
    - Isotropic surface roughness
    - Unidirectional polished surfaces

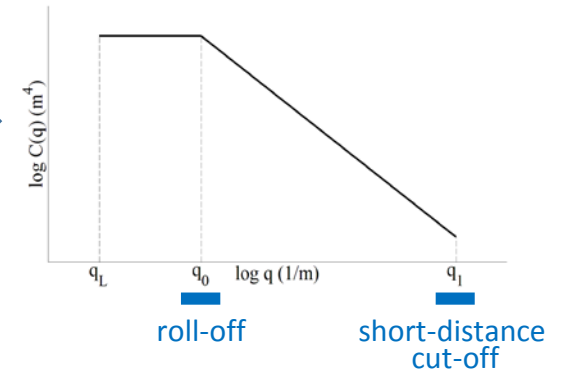
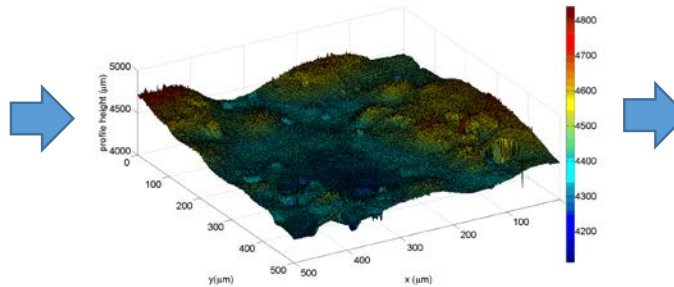



# Friction Prediction



# Physics-Based Multiscale Friction Modeling – Persson

- Hysteresis and adhesion
- Fractal and self-affine surfaces
- Depends on:
  - Rubber's frequency dependent viscoelastic modulus
  - Substrate surface roughness
  - Contact pressure
  - Sliding velocity
  - Contact temperature

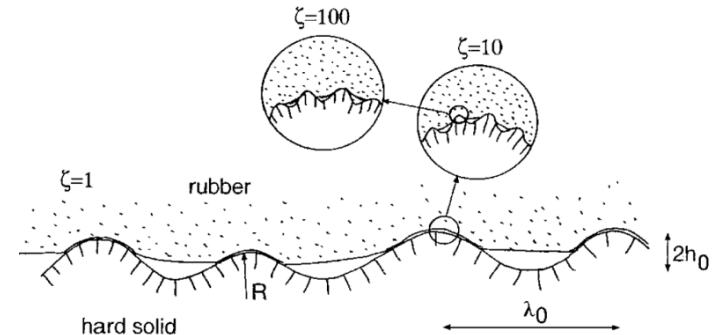

- The energy dissipation will result in local heating of the rubber.
  - The viscoelastic properties of rubber-like materials are extremely strongly temperature dependent.
  - At very low sliding velocities, the temperature increase is negligible because of heat diffusion.
- The temperature increase changes the rubber friction with sliding velocity.



$$T_q = T_0 + \int_0^{\infty} dq' g(q, q') f(q')$$

$$g(q, q') = \frac{1}{\pi} \int_0^{\infty} dk \frac{1}{Dk^2} (1 - e^{-Dk^2 t_0}) \frac{4q'}{k^2 + 4q'^2} \frac{4q^2}{k^2 + 4q^2}$$

$$f(q) = \frac{vq^4}{\rho C_V} C(q) \frac{P(q)}{P(q_m)} \int d\phi \cos\phi \operatorname{Im} \frac{E(qv\cos\phi, T_q)}{1 - \nu^2}$$

Time-temperature superposition for hysteresis is applied using the WLF equations.



# Characterization of Rough Surfaces – Power Spectrum

## One Scaling Region

$$C(q) = \frac{1}{(2\pi)^2} \int d^2x \langle h(x)h(0) \rangle e^{-iq \cdot x} \quad \xrightarrow{\text{Fractal}} \quad C(q) \approx \left(\frac{h_0}{q_0}\right)^2 \frac{H}{2\pi} \left(\frac{q}{q_0}\right)^{-2(H+1)}$$

2D

$$\bar{C}_{2D}(q) = \frac{1}{2\pi} \int_0^{2\pi} d\phi C_{2D}(q) = \frac{1}{2\pi} \int_0^{2\pi} d\phi C_{1D}(q \cos\phi) \delta(q \sin\phi) = \frac{C_{1D}(q)}{\pi q}$$

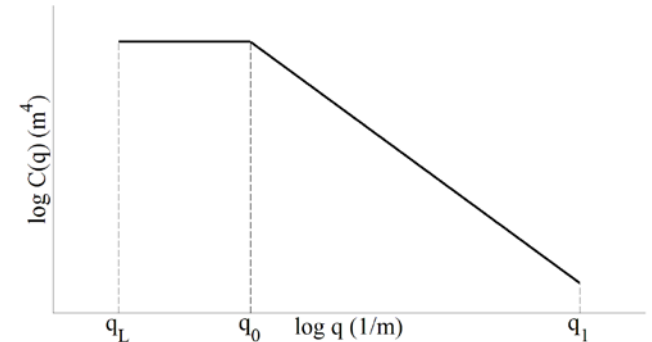

## Two Scaling Regions

$$C_1(q) \approx \left(\frac{h_0}{q_0}\right)^2 \frac{H_1}{2\pi} \left(\frac{q}{q_0}\right)^{-2(H_1+1)} \quad \text{for } q_0 < q < q_2$$

$$C_2(q) \approx \left(\frac{h_0}{q_0}\right)^2 \frac{H_2}{2\pi} \left(\frac{q_0}{q_2}\right)^{2(H_1+1)} \left(\frac{q}{q_2}\right)^{-2(H_2+1)} \quad \text{for } q > q_2$$

$q_2$ : transition length scale

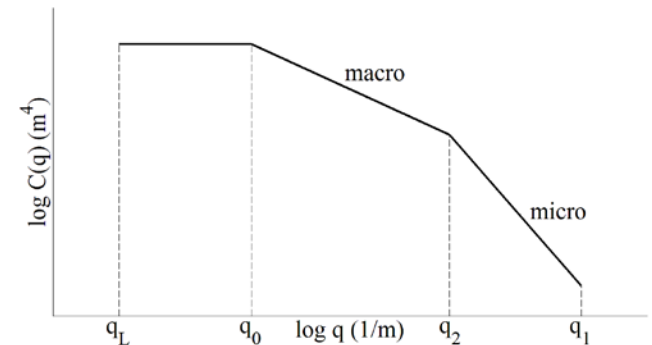

# Friction Estimation – Hysteresis

## One Scaling Region

$$\mu_k = \frac{1}{2} \int_{q_0}^{q_1} dq q^3 C(q) P(q) \int_0^{2\pi} d\phi \cos\phi \operatorname{Im} \frac{E(qv\cos\phi)}{(1-\nu^2)\sigma}$$

Kinetic Friction Coefficient

Spatial Frequency

Power Spectrum of Substrate Roughness

Real Contact Area

Rubber Viscoelastic Modulus

Normal Pressure

## Two Scaling Regions

$$\mu_k = \frac{1}{2} \left[ \int_{q_0}^{q_2} dq q^3 C_1(q) P_1(q) + \int_{q_2}^{q_1} dq q^3 C_2(q) P_2(q) \right] \int_0^{2\pi} d\phi \cos\phi \operatorname{Im} \frac{E(qv\cos\phi)}{(1-\nu^2)\sigma}$$

Macro-texture

Micro-texture



# Friction Estimation – Adhesion

At low slip speeds, contribution to friction from adhesion in the contact area is dominant.

Adhesive Friction Coefficient

$$\mu_{adh} = \frac{F_{adh}}{F_0} = \frac{\tau_f(v, T) A(\zeta_1)}{\sigma_0 A(\zeta_0)}$$

↓
↓

Normal Load
Real Contact Area

Velocity and Temperature Dependent Shear Stress

$$\tau_f = (\mu_{exp} - \mu_{hyst}) \sigma_0 A(\zeta_0) / A(\zeta_1)$$

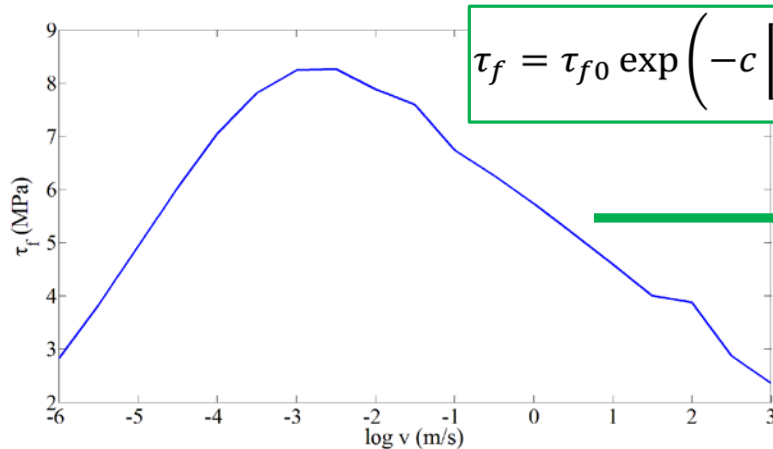

$$\ln a'_T = C'_1 \left( \frac{1}{T} - \frac{1}{T_g} + C'_2 \right)$$

$$\tau_f(v, T) = \tau_f(a'_T v, T_0)$$



# Texture measurement resolution and evaluation length (upper and short-distance cut-off lengths)

## Asphalt:

### ➤ Upper cut-off:

- ❑  $\lambda_0 \sim 1 \text{ cm}$  (typical grain size)
- ❑  $\lambda_L$ : largest relevant wavelength  
(largest sand particles in asphalt)

### ➤ Short-distance cut-off:

- Atomic distance
- Surface is covered by small dust or sand particles with typical diameter  $D$ ,  $q_1 = 1/D$
- Water trapped in surface cavities
- Clean dry surfaces
  - Layer of modified rubber at the surface (resulted from the thermal and stress-induced degradation)  $\approx 1 - 10 \mu\text{m}$

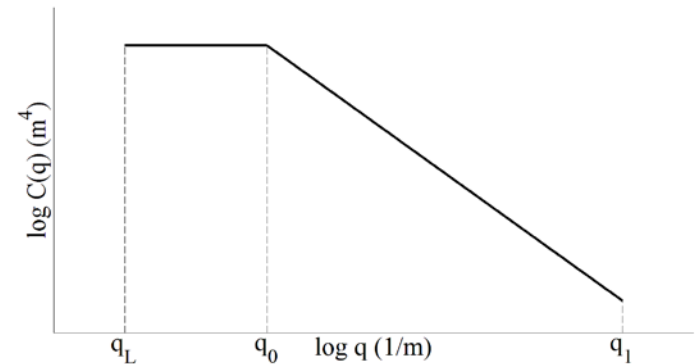

# Real Area of Contact

SBR – CB  
(small strain)

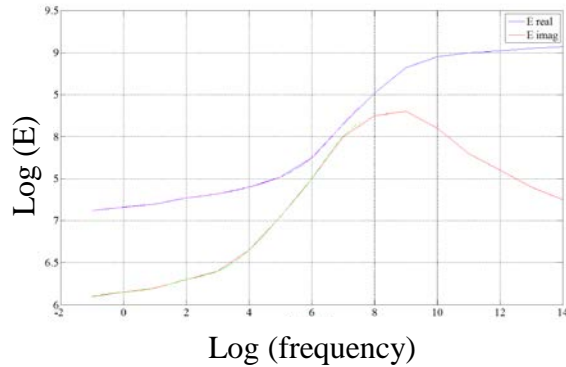

Tread Compound (Large Strain)

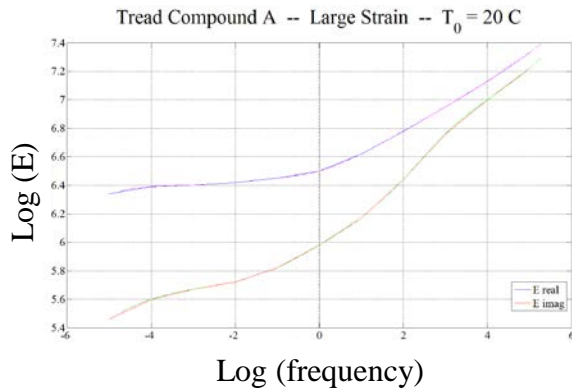

Real Area of Contact vs. Magnification

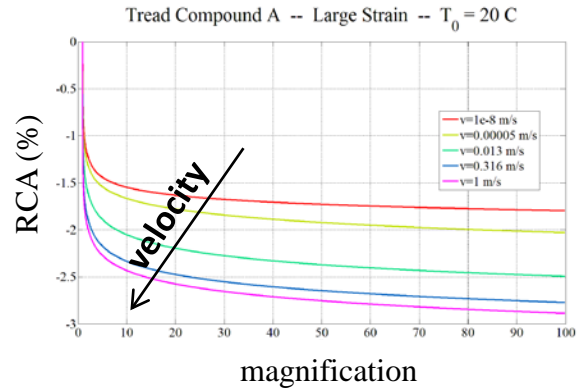
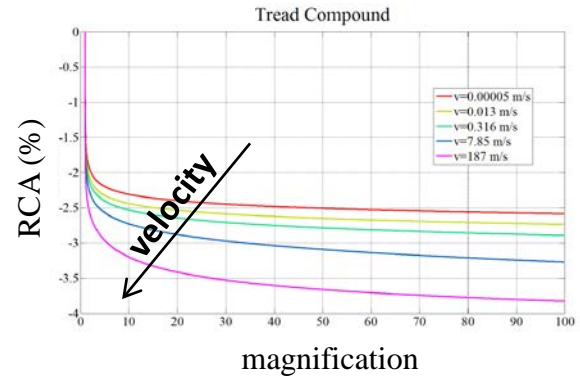

RCA increases when using large strain moduli

Using the modulus data for a real tread compound, the RCA ratio is  $\sim 1\%$  for ABS-braking sliding velocities.



# Sensitivity to Pavement Parameters

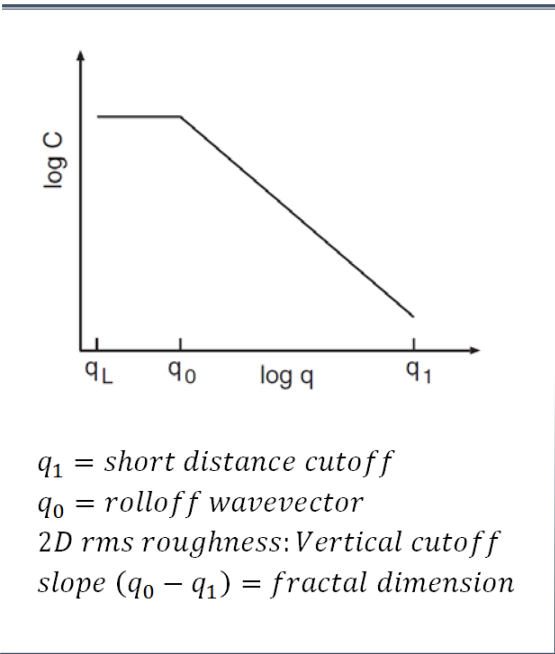

Short distance cut-off wavelength

Roll-off wavelength

Vertical cut-off

Fractal dimension

PSD vs. Frequency

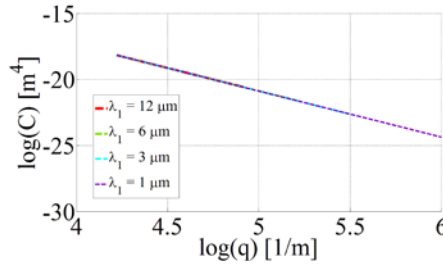

Friction vs. Velocity

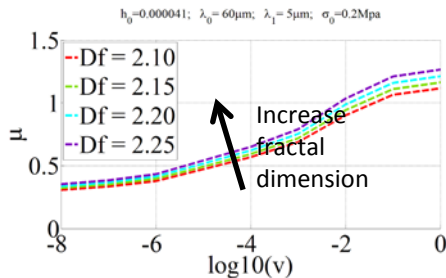
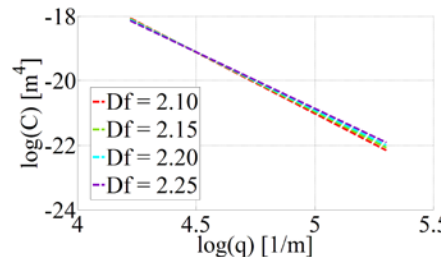
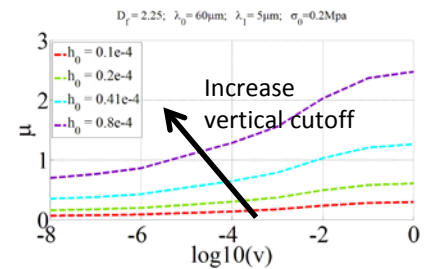
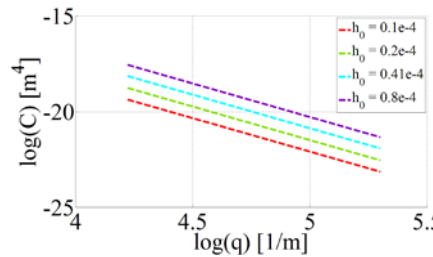
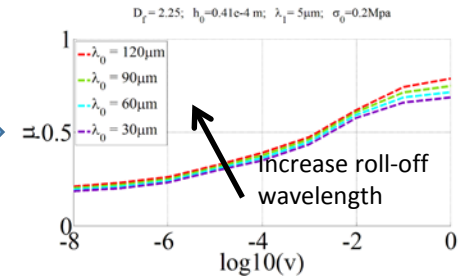
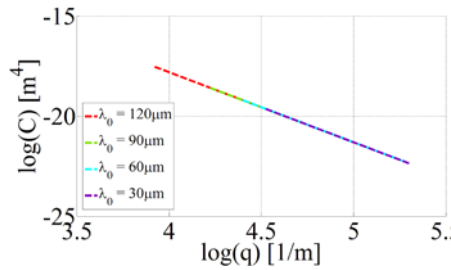
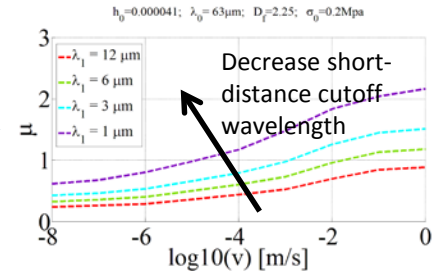





# Contribution of Different Length Scale Ranges to Friction

- **Surface segmentation:**

1. Take the complete original surface
  - Contributions from wavelength bands add up to the friction value of the original surface with all the length scales.
2. Breaking the roughness into several independent surfaces.
  - Leads to a higher friction coefficient than the original surface.

- **Rubber Mastercurves:**

- Large Strain
- Low Strain

- **Frequency Bands:**

- Linear Spatial Frequency Bands
- Logarithmic Length Scale Bands
- Linear Length Scale Bands
- Friction vs. Continuous Length Scale



➤ One Surface (sandpaper) -- Tread compound (large strain)

➤ Linear wavevector bands

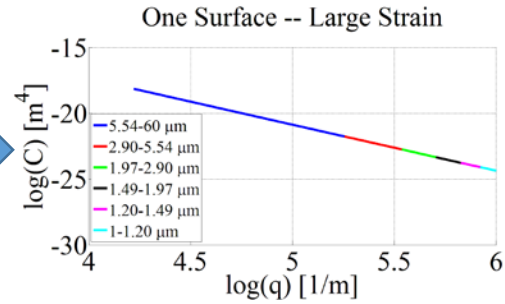
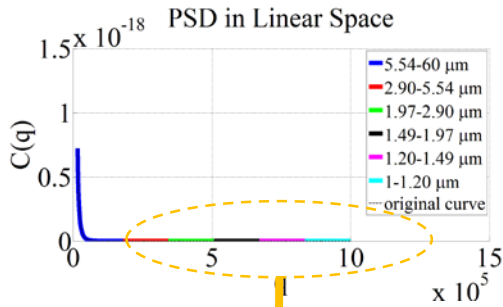

Friction is very sensitive to the short-distance cut-off wavelength.

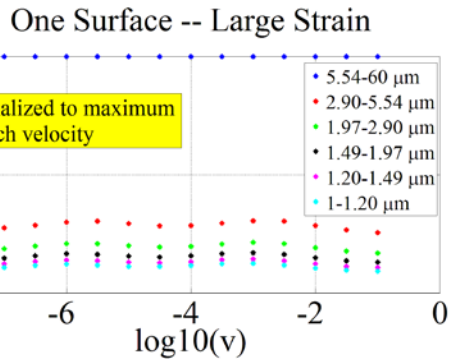
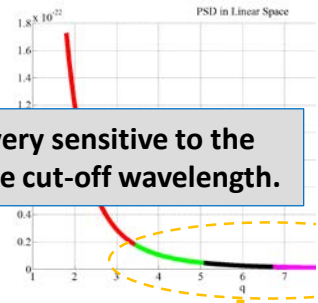

Wavevector in linear scale is the integration variable in friction estimation.

Monotonic decrease in contribution of linear wavevector bands.

Logarithmic Length Scale Bands

Every decade in length scale is roughly equally important

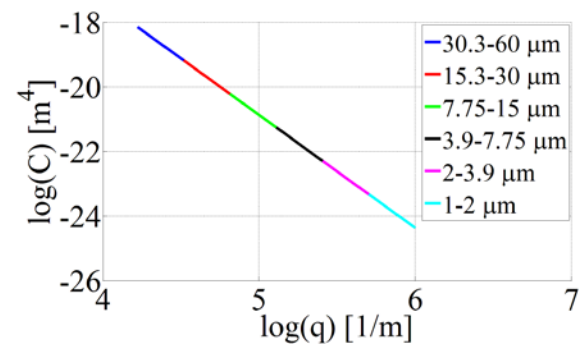
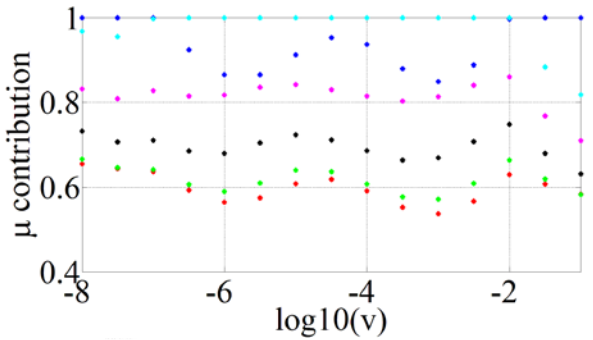
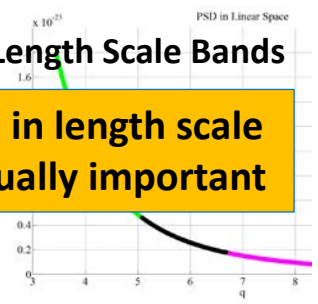

# Constant $\tan\delta$

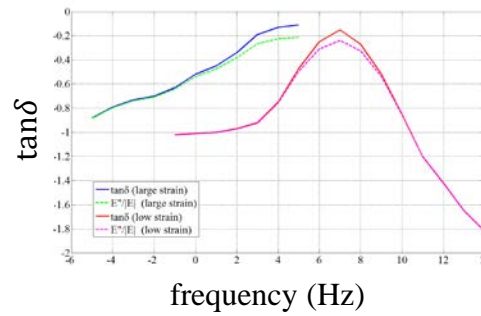
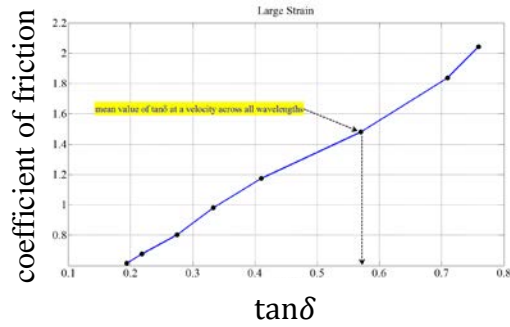

$\tan\delta: \text{const.}$

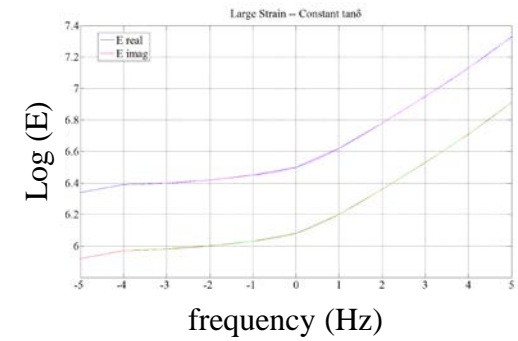

One Surface - Large Strain - Log Bands

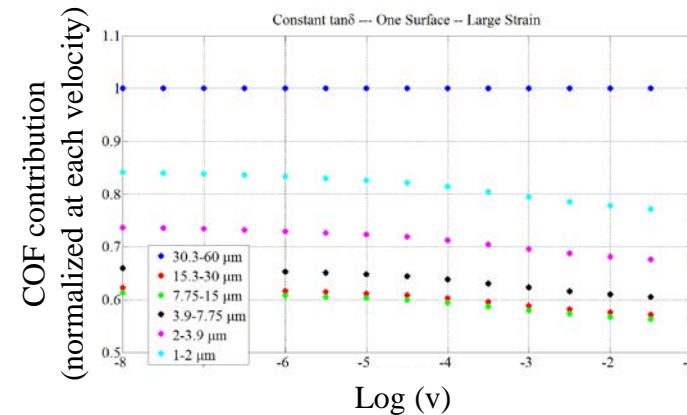
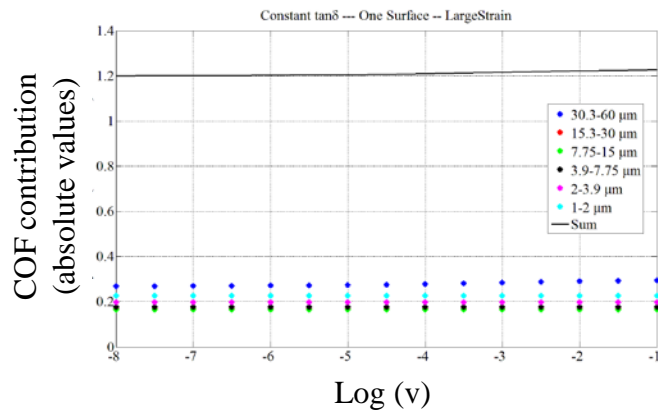

Every decade in length scale is roughly equally important.



# Effect of Short-Distance Cut-Off Wavelength

- Coefficient of friction is very sensitive to the short-distance cut-off wavevector.

- $q_1$  can be measured.
- $q_1$  can be roughly estimated, analytically.

- ❑ The contribution from the area of real contact has opposite  $q$ -dependency.
- ❑ For wet surfaces at high enough sliding speed, the contribution from the contact area (adhesion) may be very small.
  - But then the effect of flash heating becomes more important and reduces friction.

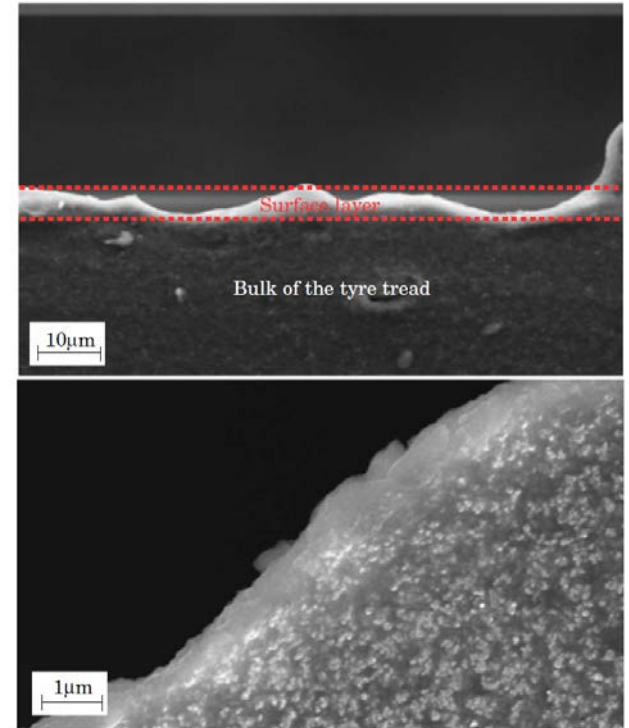

- **Thus, adhesion at low velocities, and flash heating at high velocities may make friction less  $q_1$  dependent.**

# Mean Penetration Depth

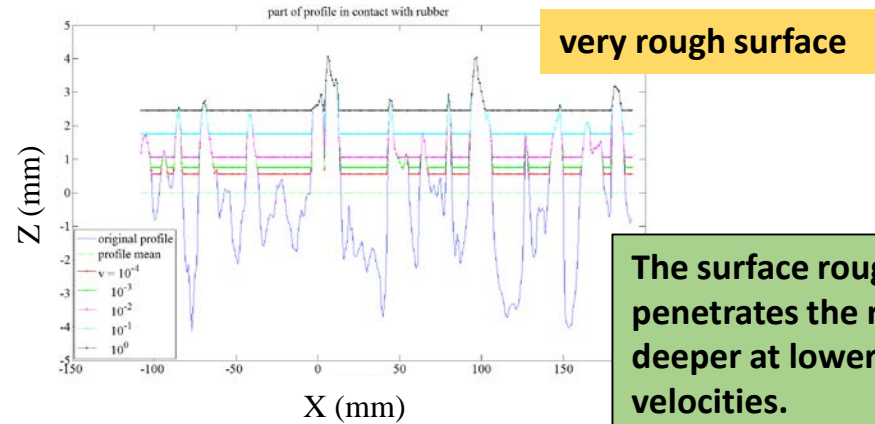
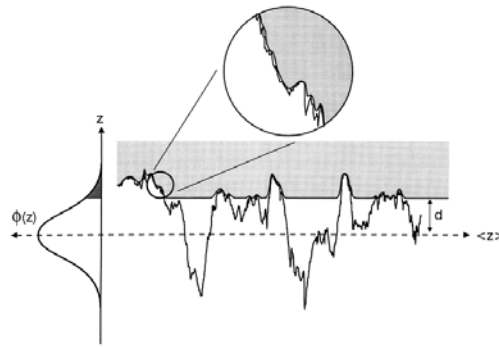

## Thickness of the Excited Layer of Rubber

- Assumed to be proportional to the mean penetration depth.
- The mean penetration depth is a function of surface roughness, sliding velocity, compound properties and pressure.
- It cannot be evaluated exactly. Excited layer estimated via a quantitative characterization of strain field in the vicinity of the surface asperities:
  - Indentation experiments monitored by photogrammetry
  - Finite element simulations
- Ratio of (excited layer thickness) / (mean penetration depth):
  - 1.1 – 2.6 for SBR-CB on asphalt @  $P = 12 \text{ kPa}$ .
  - The ratio can increase with pressure:
    - ❑ For passenger tire, typical pressure is  $0.3 \text{ MPa}$ , and  $0.8 \text{ Mpa}$  for truck tire.
    - ❑ These pressures give the penetration depth as  $0.03 \text{ mm}$  and  $0.08 \text{ mm}$ , respectively.
    - ❑ These values are below the rms roughness of typical road tracks ( $0.1 \text{ mm}$ ).
    - ❑ The thickness of the excited layer is  $0.5 - 1.0 \text{ mm}$ .

# Friction Measurement



# Dynamic Rubber Friction Tester (DRFT)

- Tire tread sample embedded in the measuring arm.
  - Four tread compounds (Bridgestone)
- “Fake road surface” disk with an arbitrary surface.
  - Sandpaper
- ❑ Rubber sample and the disk independently driven at specific speeds.
- ❑ Friction measurements at different slip ratios.

## Control and Data Acquisition

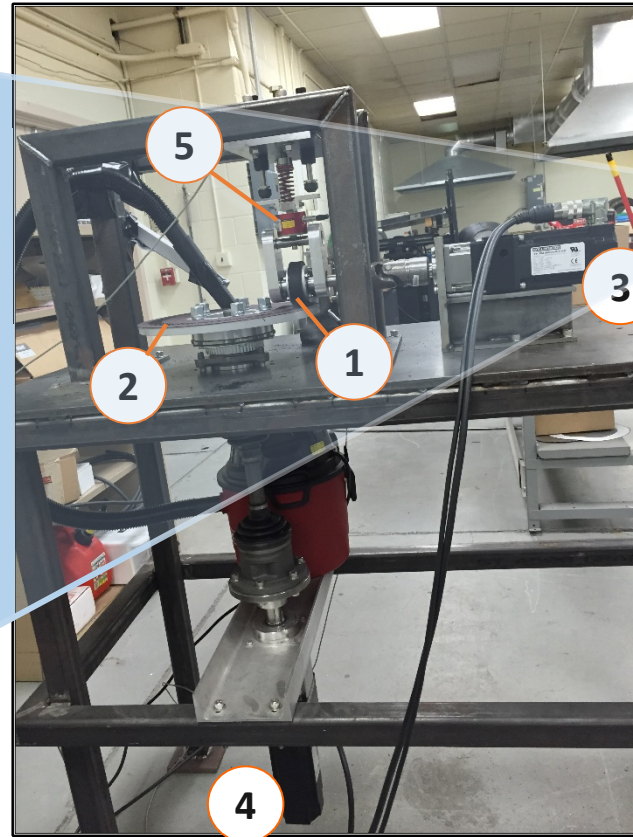
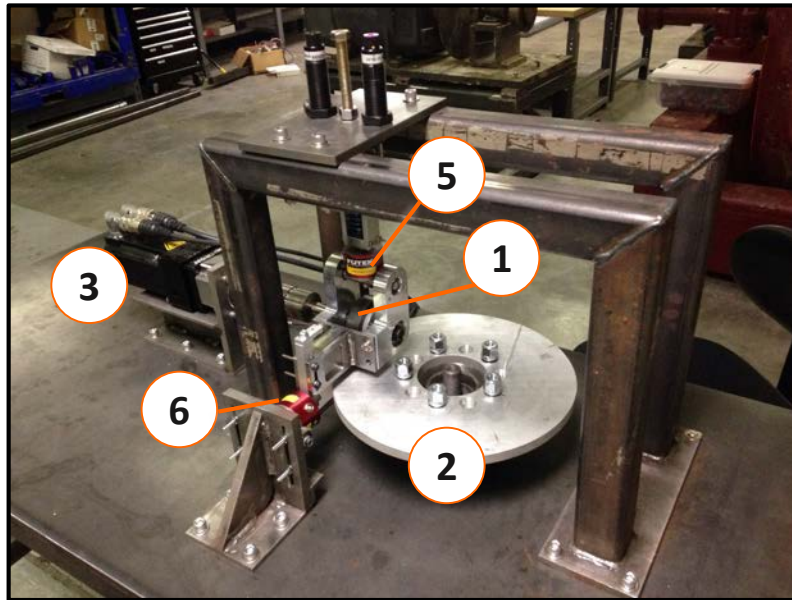
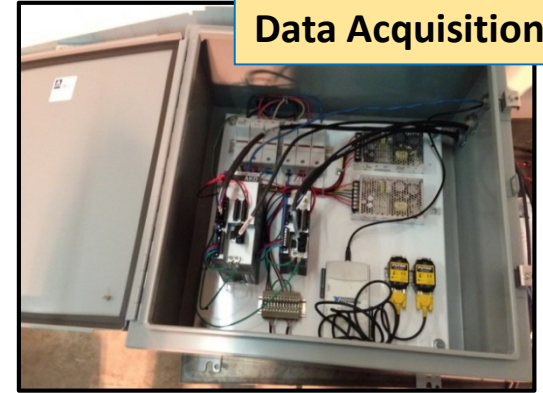

## DRFT

- (1) rubber sample
- (2) surface disk
- (3) sample drive
- (4) disk drive
- (5) normal load
- (6) friction load



# DRFT – Climate Control Chamber

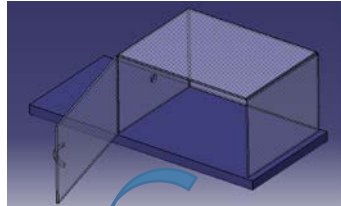

Standard Refrigeration and Humidity Control System:

- Temp:  $-20\text{ F}$  to  $150\text{ F}$  ( $-29\text{ C}$  to  $65\text{ C}$ )
- Humidity: 10 – 98%

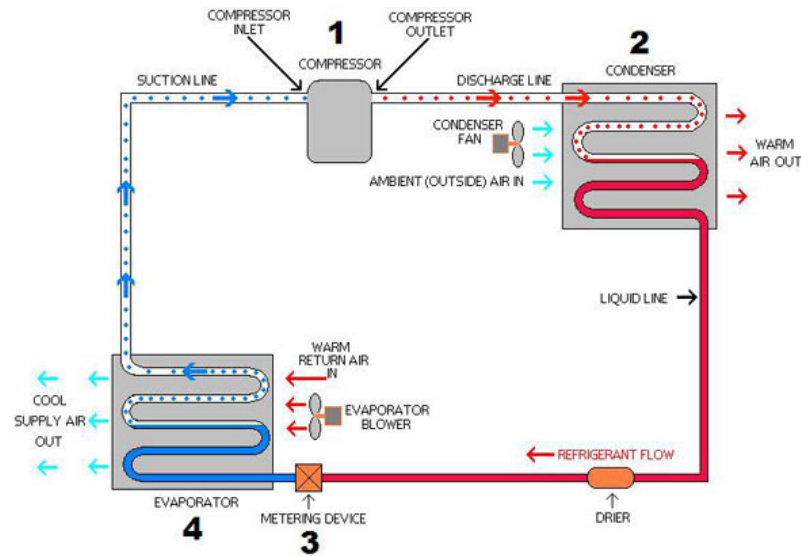
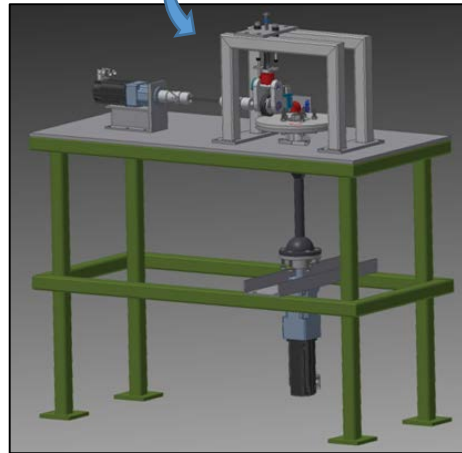

Icy Road

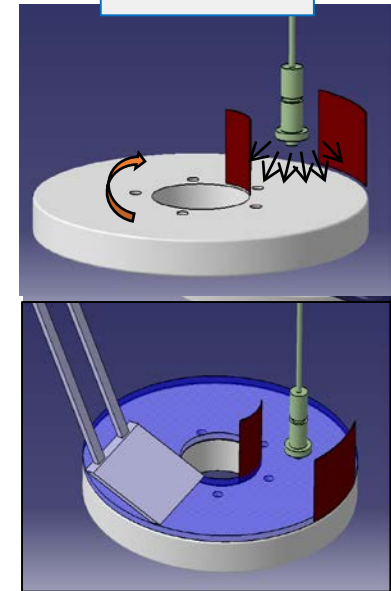



# DRFT – Results

## • Friction vs. Longitudinal Slip

- All-season tread compound on 120-grit sandpaper
- Friction reaches its peak at ~15-20% slip ratio.
- Consistent with the data in the literature.

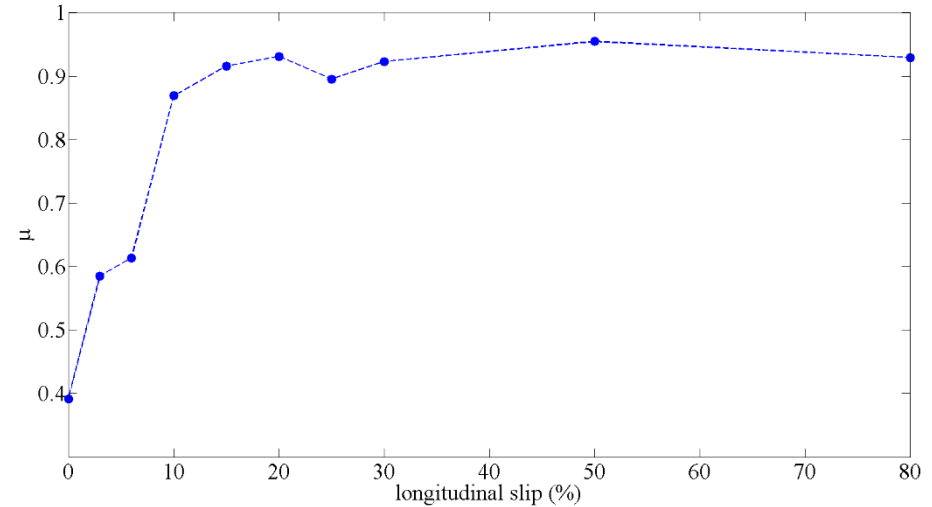

## • Friction vs. Speed

- A summer tire tread compound on 120-grit sandpaper.
- For velocities greater than ~ 10 *cm/s*, adhesion becomes less effective and therefore friction coefficient decreases with speed.

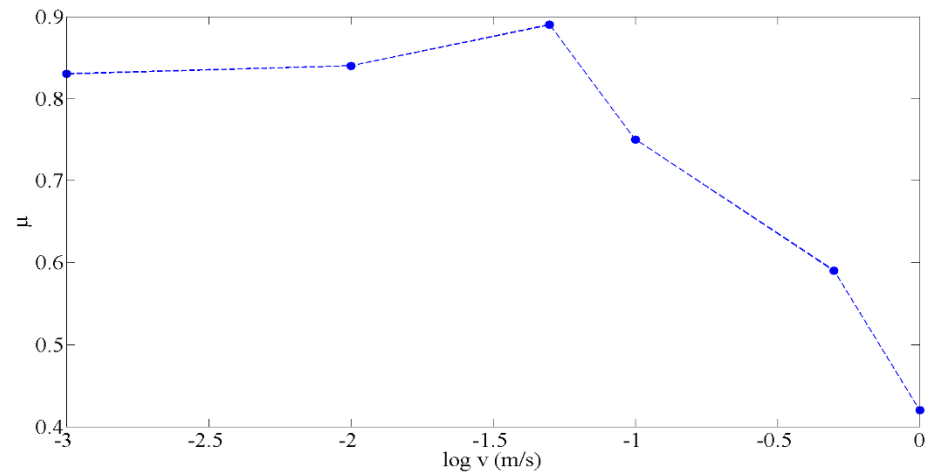

# Comparison of Theory and Indoor Experiments

## Surface Characterization Two Scaling Regime

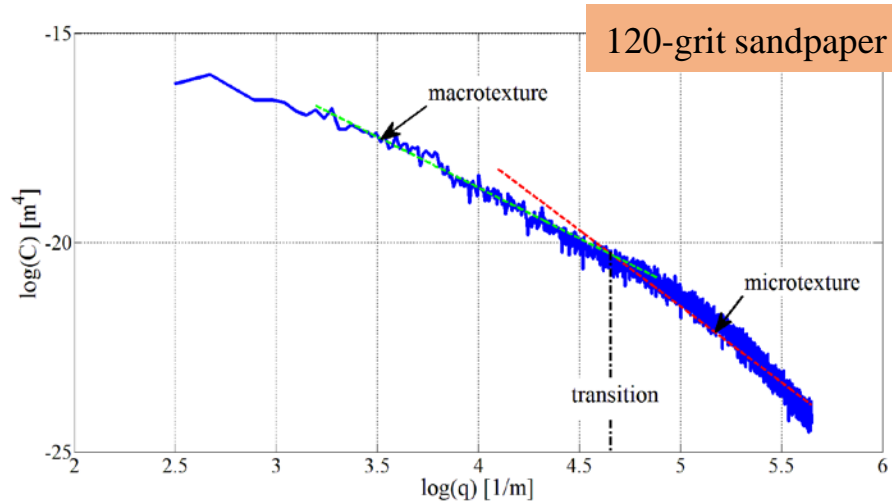

- $\lambda_2 \approx 150 \mu m$
- $D_f$  (one regime) = 2.30
- $D_{f1}$  (macro) = 2.69
- $D_{f2}$  (micro) = 2.18

## Friction Estimation (Hysteresis and Adhesion) One and Two Scaling Regimes

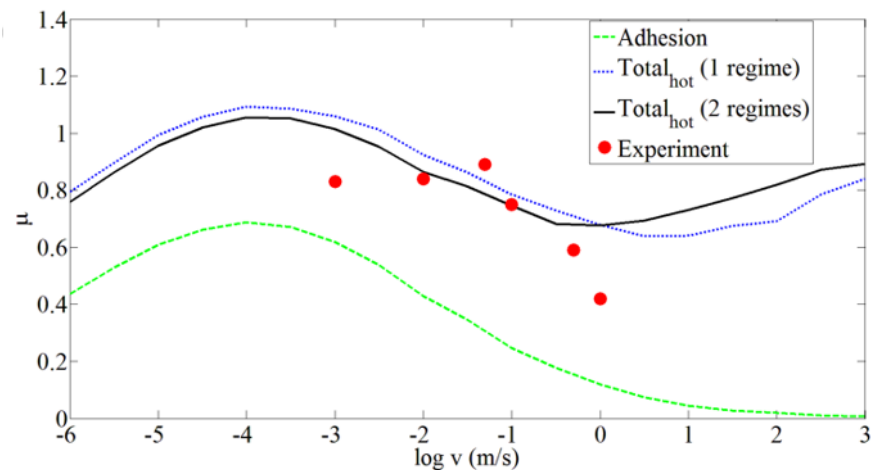
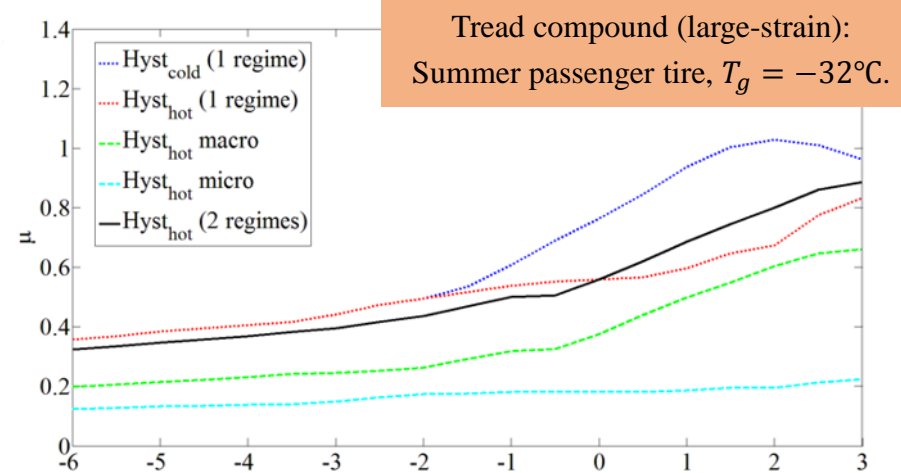

# Summary

- Predicting friction between any given tread compound and road:
  - Measure the profile of road surfaces
  - Parameterize the profiles using only 1D measurements
  - Test and characterize tire tread compounds
  - A multiscale rubber friction model
- Physics-based friction prediction:
  - Gain a meticulous understanding of rubber-road contact mechanics
    - Hysteresis and Adhesion
    - Real Area of Contact
    - Sensitivity to Pavement Parameters
    - Thickness of the Excited Layer of Rubber
- Dynamic Friction Tester
- Correlation between theory and indoor experiments



**Thank you**

